

# CONSPIT CPP EVO

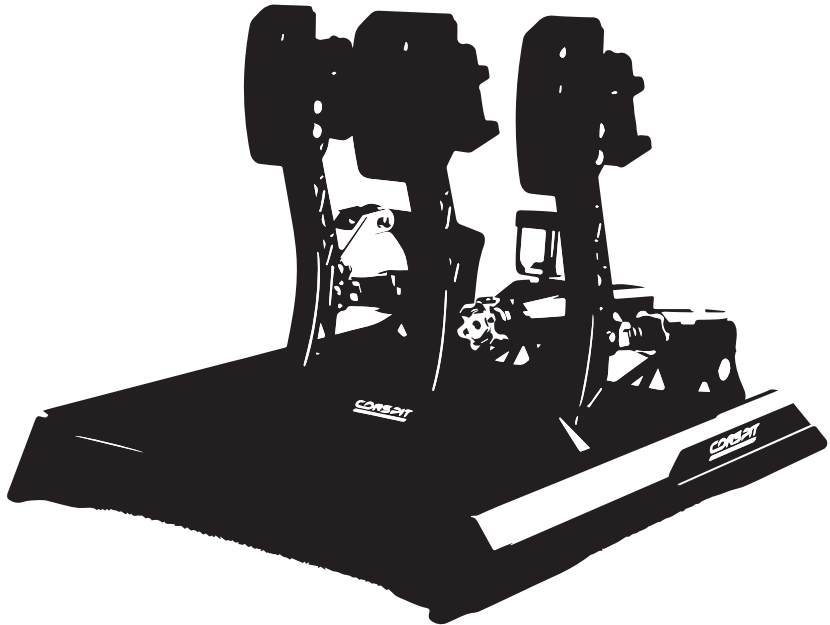

## Quick Guide

|  |    |
|--|----|
| <b>Product Disclaimer</b> .....                                | 1  |
| <b>Packing List</b> .....                                      | 4  |
| <b>01 Install the CPP EVO to the Base Mounting Plate</b> ..... | 5  |
| Recommended position of pedals.....                            | 5  |
| Cable routing path.....  | 6  |
| Mount the pedal set to the base mounting plate .....           | 6  |
| Connect all cables .....                                       | 7  |
| <b>02 Install the Pedal Set to the Rig</b> .....               | 9  |
| Mount CPP EVO to the rig .....                                 | 10 |
| Mount CPP EVO to Aluminum Profile-based Rig .....              | 11 |
| <b>03 Fine Tune Your CPP EVO</b> .....                         | 12 |
| Pedal pads angle adjustment .....                              | 12 |
| Pedal pads height adjustment .....                             | 13 |
| Throttle pedal feel adjustment .....                           | 13 |
| Brake pedal feel adjustment .....                              | 14 |
| Clutch pedal feel adjustment .....                             | 17 |
| <b>04 Software Installation and Set-Up</b> .....               | 18 |
| Download Conspit Link 2.0 .....                                | 18 |

# Table of Contents

- Please read the manual carefully before you use the pedal set
- Any **modifications, tampering, changes or unauthorized uses** of the product will void the warranty
- The pedal set has no waterproof feature, please keep it away from water, rain, moisture and other items containing liquid
- This pedal set is exclusively designed for sim-racing
- Disconnect the USB cable if you will not use the product for a long time

**\*Please note the serial number on your product before contacting the support. The serial number can be found on the inner and outer packaging, control board and warranty card, and written here for your convenience.**



# Product Disclaimer

We hereby reminds you that:

Before using this product, please ensure that you have carefully read and fully understood this Product Disclaimer and all the following product safety tips and operation specifications. To the extent permitted by the laws of the People's Republic of China, Ensu (Shanghai) Electronic Technology Co., Ltd. is not responsible for all personal injury and/or property damage caused by your failure to obey any of the following safety tips or operating specifications.

If you have any questions about this Disclaimer or the following product safety tips and operating specifications, you can consult through [support@conspit.com](mailto:support@conspit.com). In the process of reading this Disclaimer and the following product safety tips and operating specifications, you should immediately stop using this product if you do not agree with any of the contents. If you do use this product, your behavior will be regarded as an acceptance of this Disclaimer and the following product safety tips and operation specifications.

- **It is essential to use this product under safe conditions:**

Please ensure that the user has the ability to move independently and is conscious. Do not use this product when sick, fatigued, or under the influence of alcohol/drugs.

- **Ensure proper installation of the product:**

This product requires you to complete some installation work. Make sure that all parts of the bracket are properly and securely installed. Please follow the steps and instructions in the product manual during the installation process. Using the product without proper installation may result in the following: partial fasteners coming loose and causing collision injuries, parts detaching and causing injury to yourself or others.

- **Prevent excessive use of force.**

During the design and production of this product, large structural strength and safety redundancy have been considered to prevent parts from falling off. However, improper force application beyond the normal use range may cause damage to the components, resulting in potential safety risks.

- **Situations that may pose hazards during normal use include, but are not limited to:**
  - Other people or pets coming close to the user's operating area.
  - Electrical cables near the working area of pedals, steering wheels, and other moving parts.
  - User's foot slipping off the pedal when applying force.
  - Do not use this product without shoes
  
- **Follow all safety tips and operating procedures:**
  - Avoid using the product for an extended period - prolonged continuous use may cause fatigue, muscle pain, or other negative effects. We recommend a maximum single-use time of 2 hours, and the daily maximum recommended usage time should not exceed 6 hours.
  - Prohibit independent use by children under 12 years old, this product is not designed for use by children. Children should use this product under the supervision of their guardian.
  
- **Malfunctioning and damaged products:**
  - If the product is damaged or cannot be used properly, please stop using it immediately and consult CONSPIT's after-sales customer service. Continuing to use it may cause further damage to the product.
  - Do not attempt to repair the product or its accessories by yourself.
  - CPP hydraulic brake system contains hydraulic oil. If user finds oil leakage, damage, etc., please contact customer service immediately. Unauthorized disposal of hydraulic oil may cause injury (including swallowing, slipping and other injuries).
  
- **General preventive measures:**
  - Please store and protect the product and its accessories properly.
  - Do not immerse the product in liquid.
  - Do not use the product in any environment with flammable substances.
  - Using the product in dusty or dirty locations may cause damage.
  - Do not drop the product (or its components) or subject it to physical impact.

## CONSPIT CPP EVO Pedal Set:

All-metal build, rock-solid durability. Innovative hydraulics, precision throttle tuning for smooth, nuanced control.

High-accuracy sensors, lightning-fast response.

200bar braking force, professional handling, unwavering confidence.



Please confirm all the components listed in the packing list before starting the installation.

**The installation process is expected to take 20-30 minutes.**

# Packing List



(A)  
base mounting plate



(B)  
CPP EVO 3  
throttle, brake and  
clutch pedals



(B)  
CPP EVO 2  
throttle and  
brake pedals



stickers



M8x18mm  
round head hex bolts  
(6 pieces)



M8x16mm  
hex bolts  
(4 pieces)



6.0mm hex wrench  
5.0mm hex wrench  
4.0mm hex wrench  
shortened 5.0mm hex wrench



spare parts  
(elastomers & spring)



USB type C to USB type A adapter



1.5m USB type C to USB type C

USB cable & adapter



power adapter



adjustment tools  
(Hydraulic Preload)

# 01 Install the CPP EVO to the Base Mounting Plate

## \* Precautions during installation

- The product contains small parts. Please avoid accidental swallowing. It is forbidden to disassemble modular units such as hydraulic brake system, clutch modules.
- Avoid using excessive force to prevent screw damage and other potential risks.

## Accessories required for this step



(A)  
base mounting plate



(B)  
pedals

**\* Please flip the base mounting plate first and connect all cables (including USB cables) to the control board underneath before installing the pedal to the rig.**

## Installation sequence

- (1) Mount each pedal set to recommended position on the base mounting plate (A).

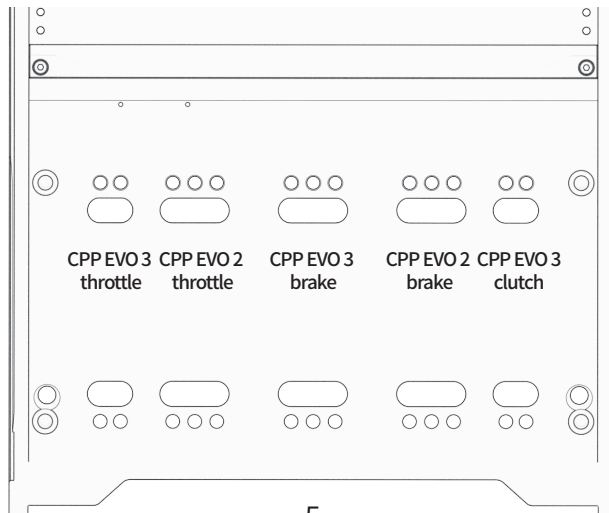



- (2) Thread all data and rumble motor cables through the lumbar hole on the base mounting plate.

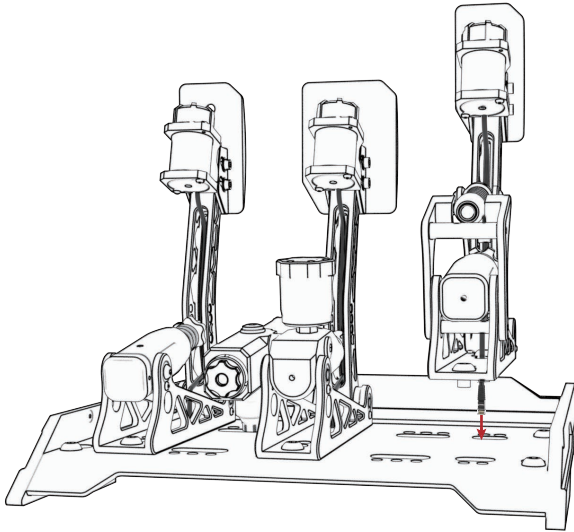

- (3) Mount the pedal set to the base mounting plate.

The figure below takes the throttle pedal as an example  
The brake and clutch pedals are installed in the same way

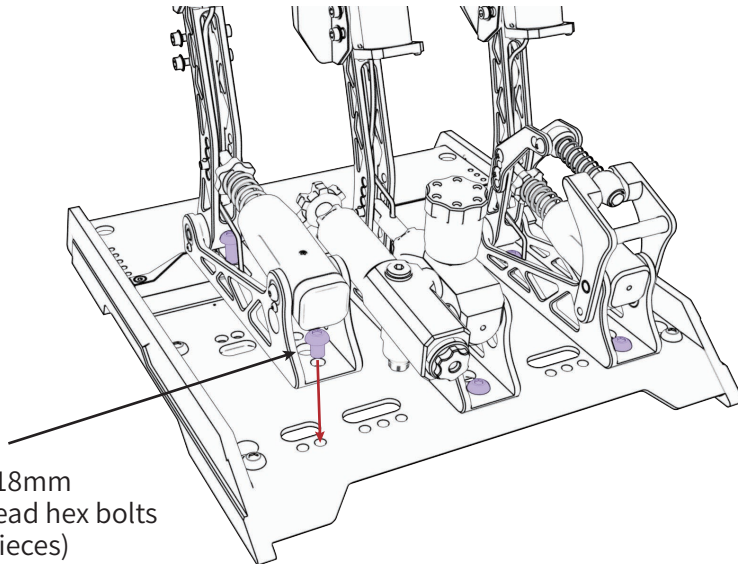

M8\*18mm  
rounded head hex bolts  
(6 pieces)

(4) Flip the base mounting plate to the bottom side and connect all cables shown as below.

\* In order to ensure the stability of data transmission, the data cable must be ensured no entanglement or crushing during assemble.

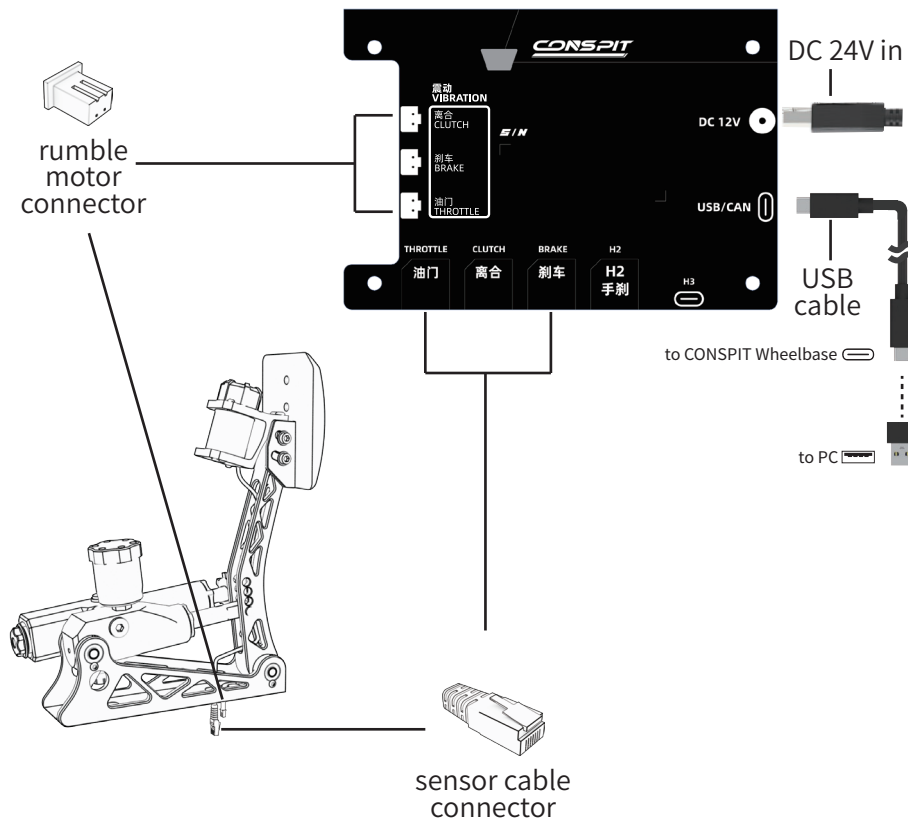

## Connection Demonstration

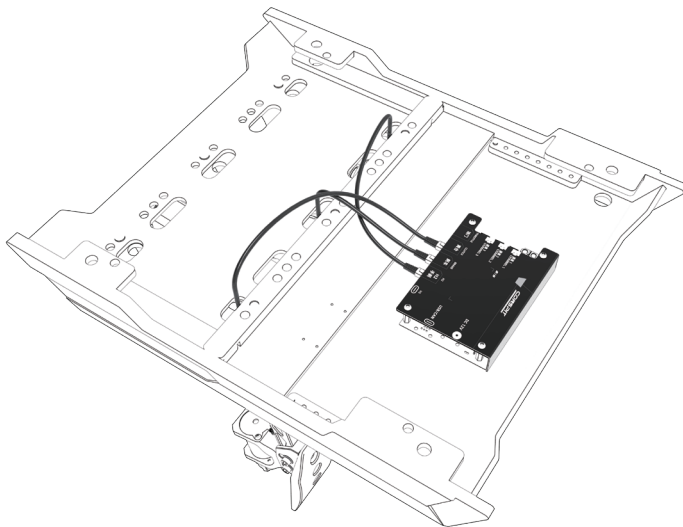

**Data Cable Connection**

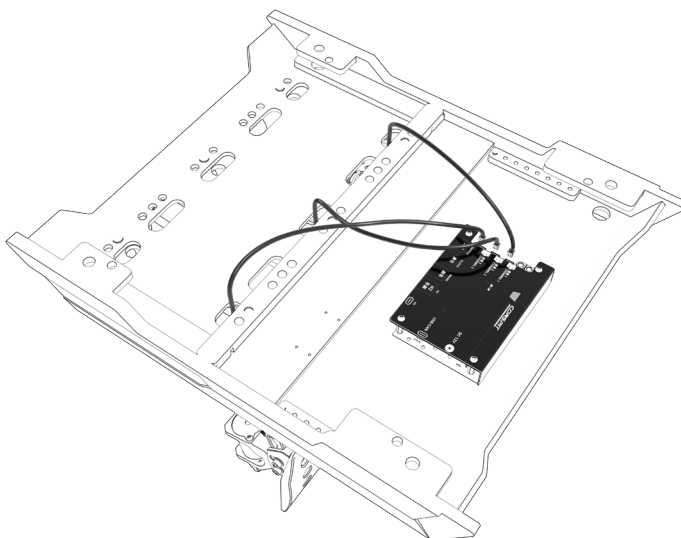

**Rumble Motor Connection**

## 02 Install the Pedal Set to the Rig

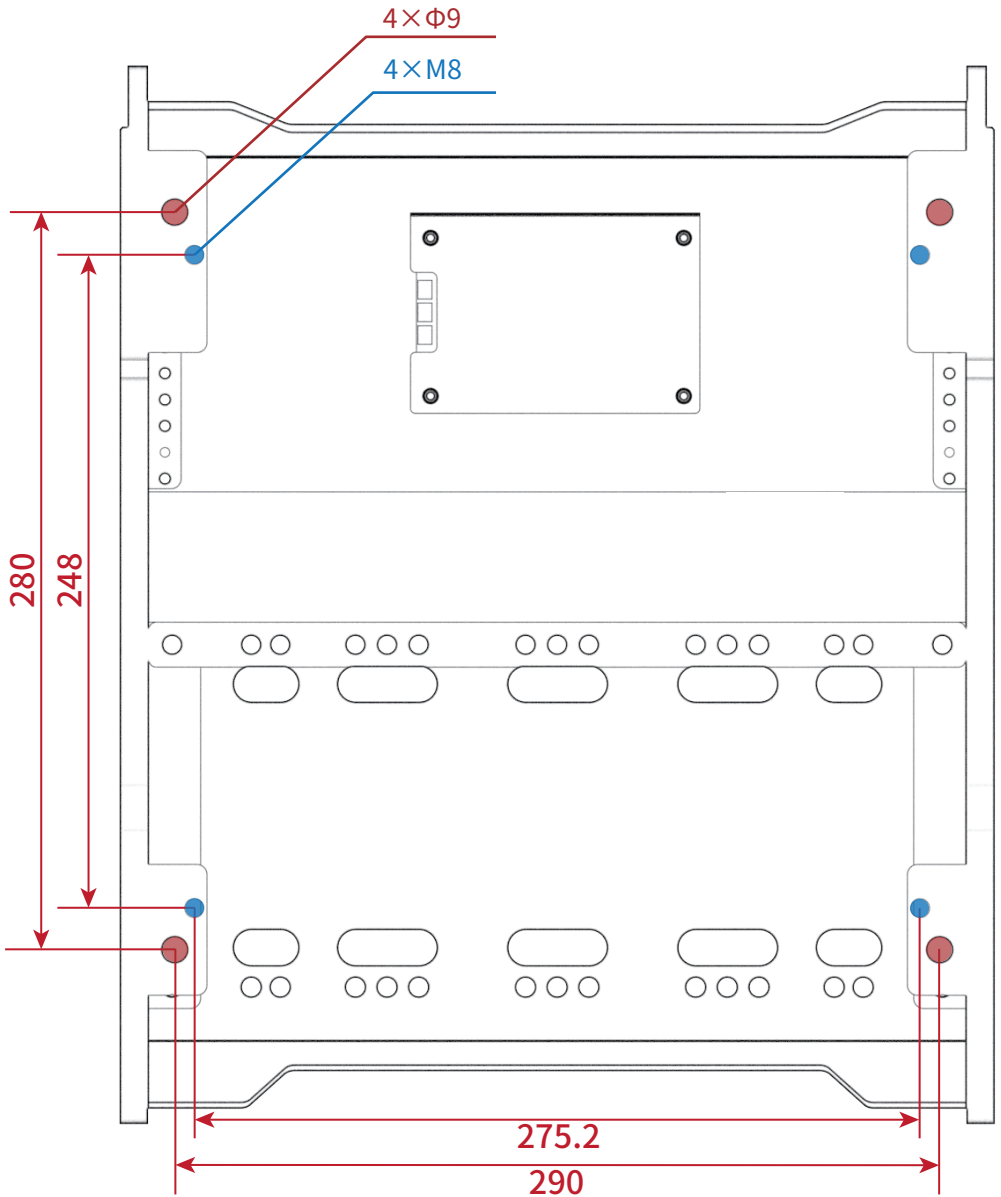

CPP EVO Drilling Template

(1) Mount CPP EVO to the rig

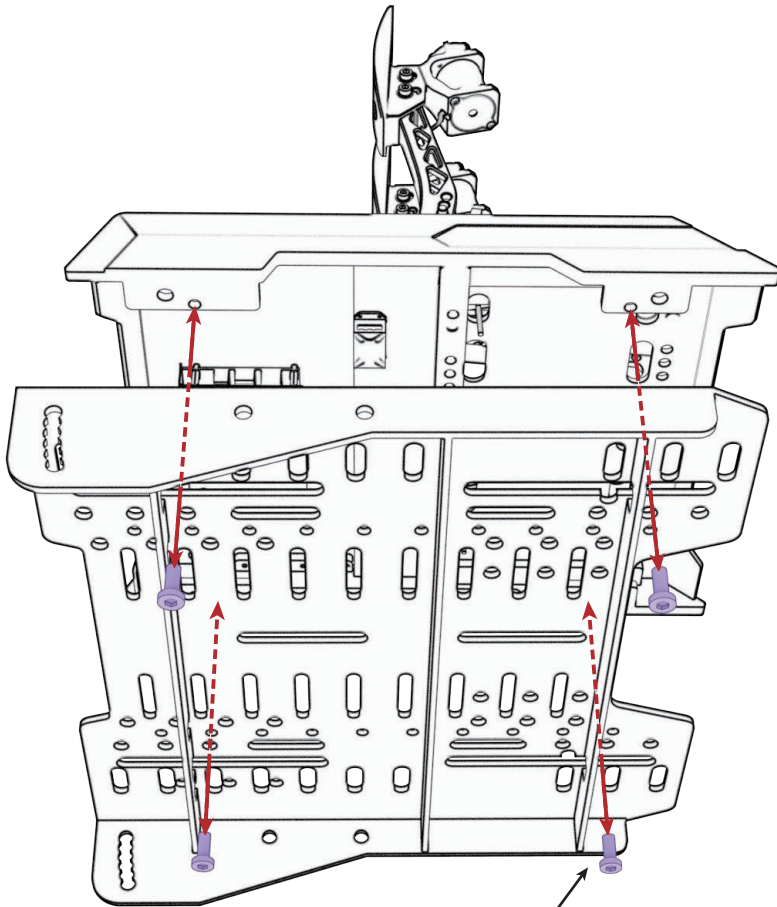

M8\*16mm hex bolts (4 pieces)

## (2) Mount CPP EVO to Aluminum Profile-based Rig

40 Series T-Slot Aluminum Profile is recommended

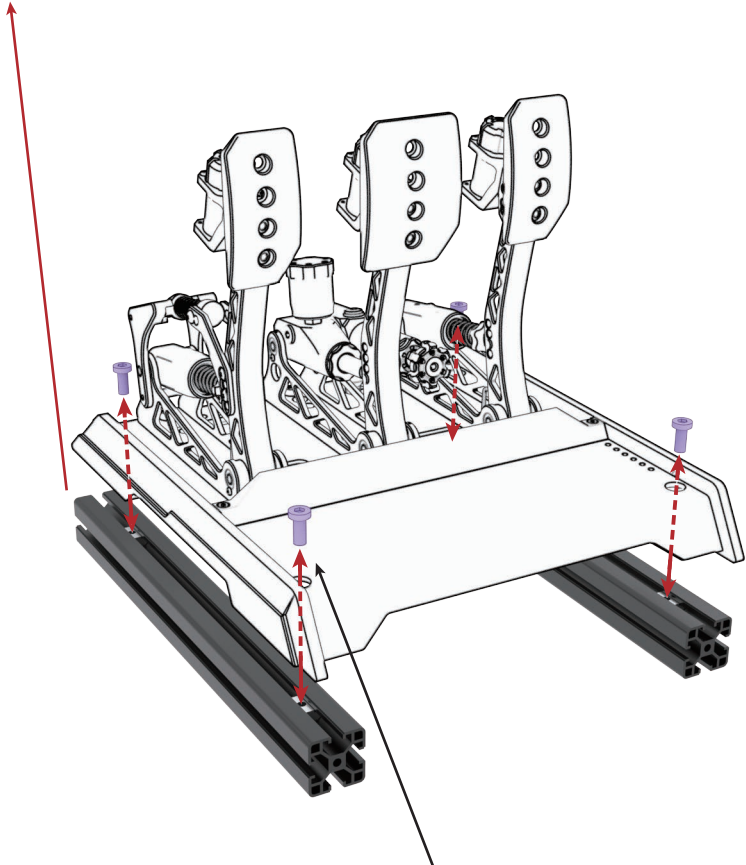

M8\*16mm hex bolts (4 pieces)

## 03 Fine Tune Your CPP EVO

CPP series provides versatile adjustable space, with throttle, brake, and clutch supporting stepwise force adjustment as well as further fine-tuning without limitations.

- **Pedal Pads Angle Adjustment**

The angle adjustment range of the pad is  $0^{\circ}$  to  $15^{\circ}$ , with  $0^{\circ}$  being when the plate is perpendicular to the pedal base.

**\*Angle recommendation:**

-Formula posture:  $0^{\circ}$ ~ $5^{\circ}$

-GT posture:  $5^{\circ}$ ~ $15^{\circ}$

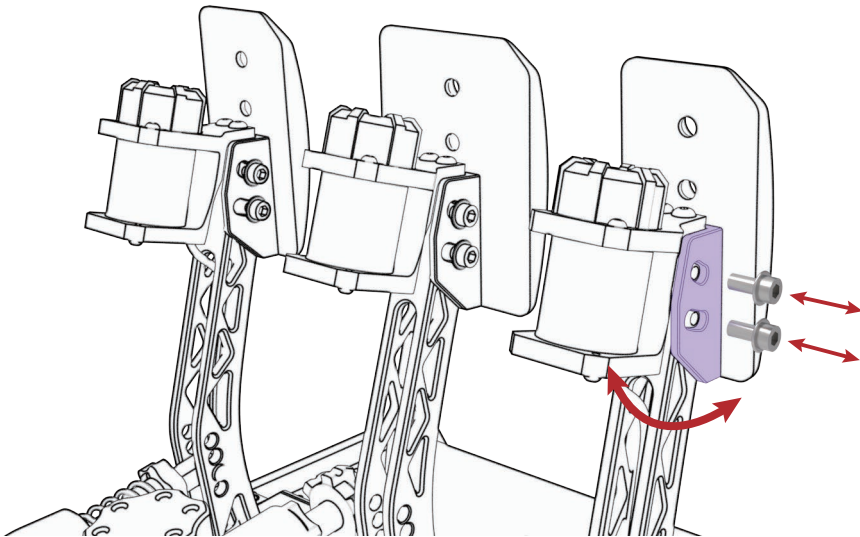

- Pedal Pads Height Adjustment

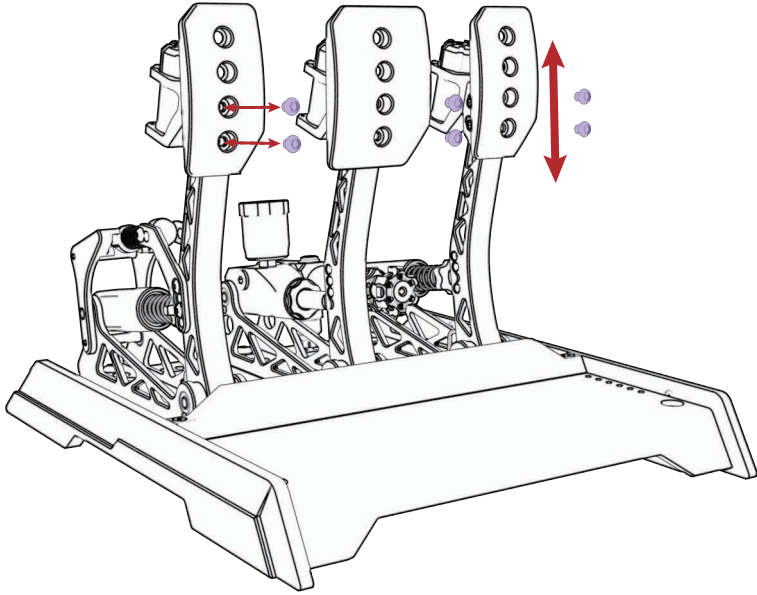

- Throttle Pedal Feel Adjustment

Different pedal force can be adjusted by changing the locking pin position. The pedal force varies with the corresponding position. Pedal force increases sequentially from bottom to top.

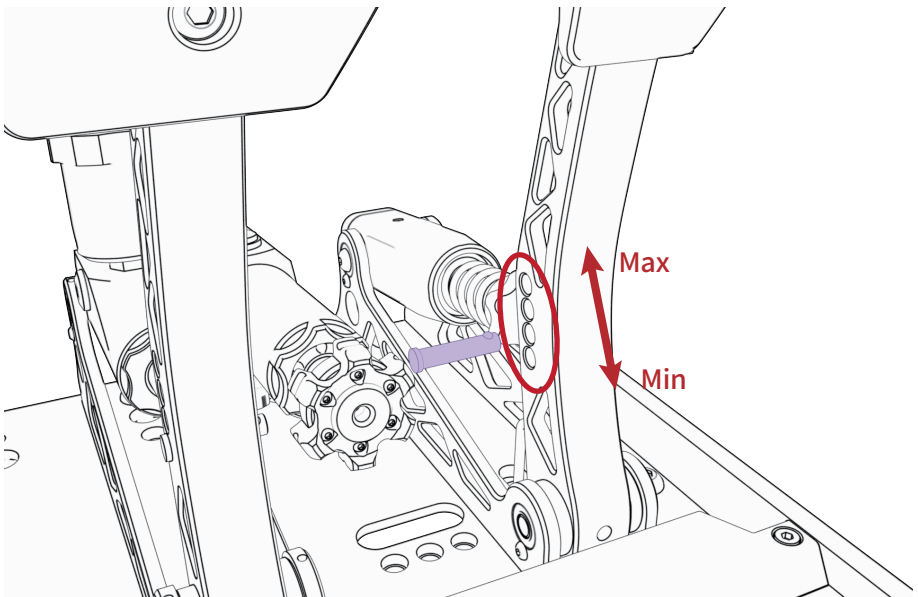



Pedal force and travel can be further fine-tuned by turning the knob.

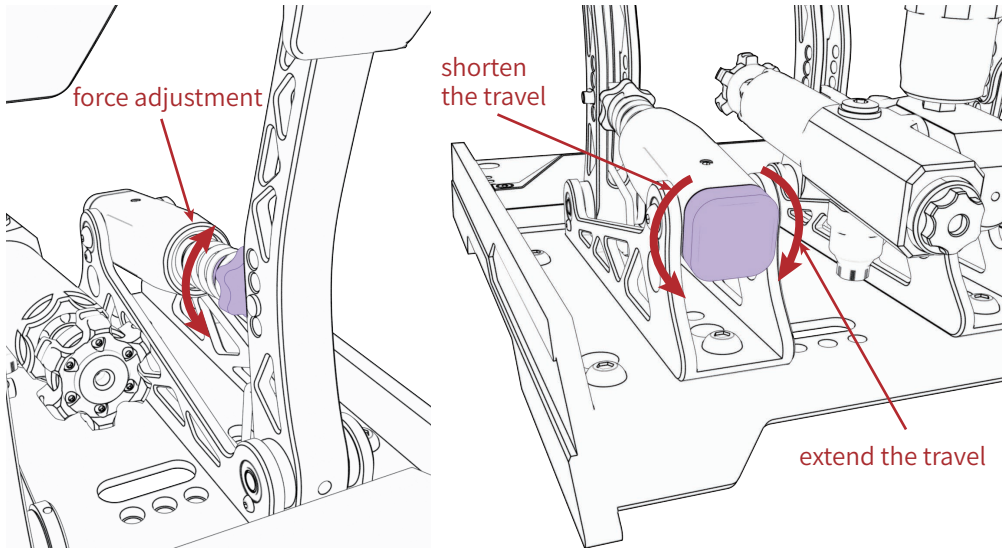

- **Brake Pedal Feel Adjustment**

By changing the locking pin position, the pedal force can be stepped change.

1. Turn the knob counter-clockwise to completely release the preload pressure

2. Press the brake pedal 1~2 times

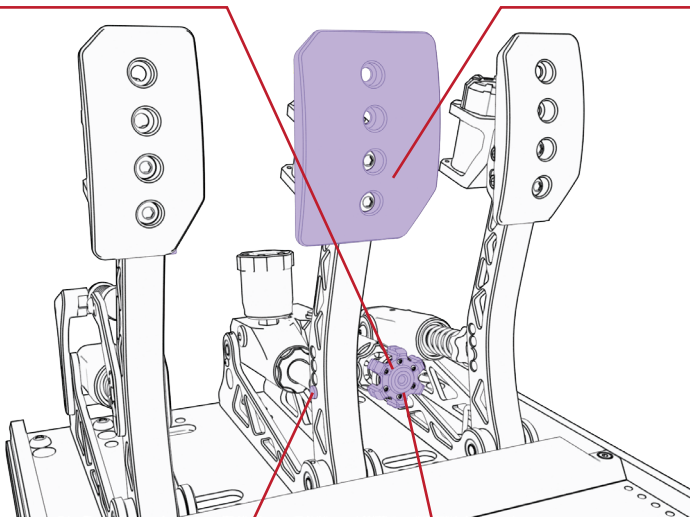

3. Change the locking pin position

4. Turn the knob clockwise to desired hydraulic preload

The four positions of the locking pin simulate different brake pedal feel of various vehicles. When the hydraulic sensor reaches its maximum capacity (100 bar), the corresponding pedal force on the pedal pad is shown in the table below:

| Type                 | Pedal Force |
|----------------------|-------------|
| • Formula Racing Car | 1440N       |
| • GT Racing Car      | 1238N       |
| • Hyper Car          | 1000N       |
| • Sports Car         | 774N        |

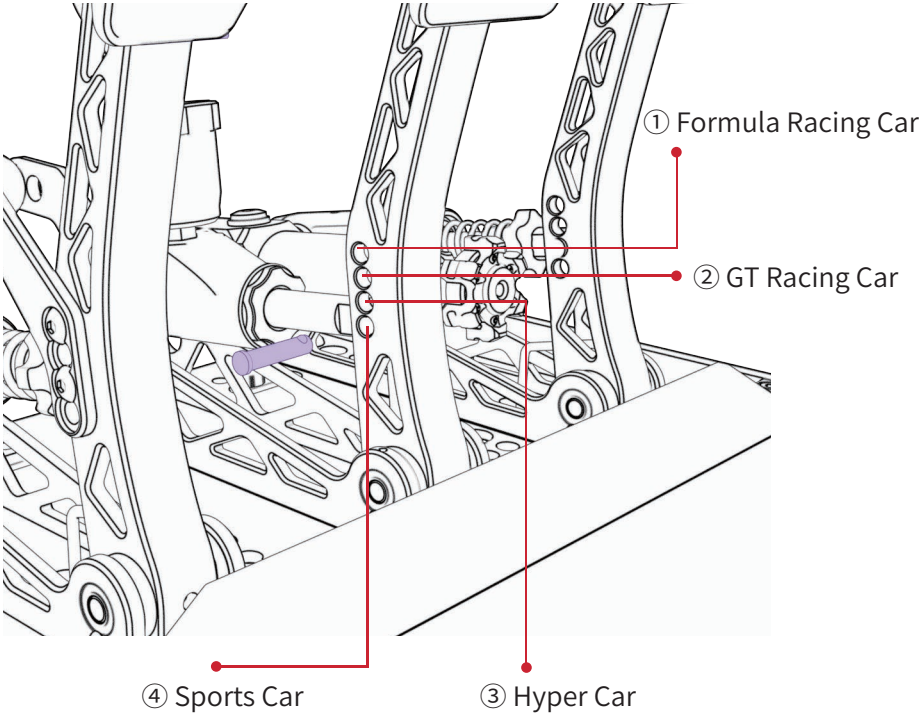

Hydraulic Preload of the brake can be adjusted by turning the knob with the adjustment tool.

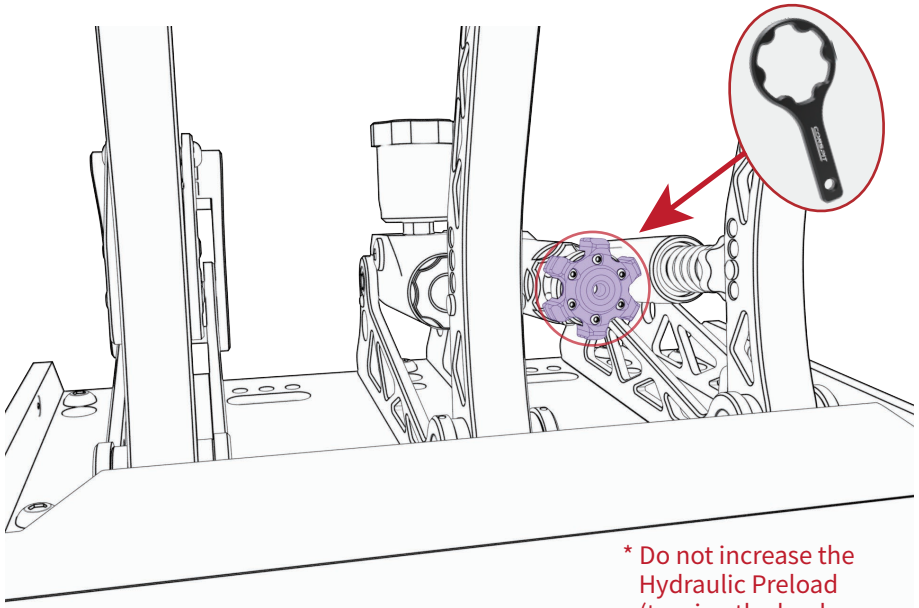

\* Do not increase the Hydraulic Preload (turning the knob clockwise) excessively

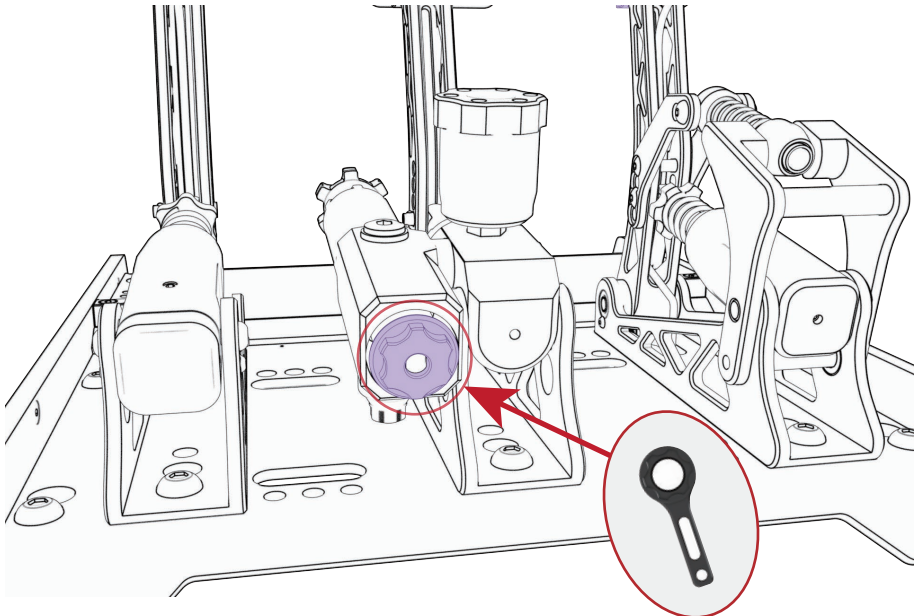

- **Clutch Pedal Feel Adjustment**

The clutch travel and engagement point can be adjusted by turning the knob.

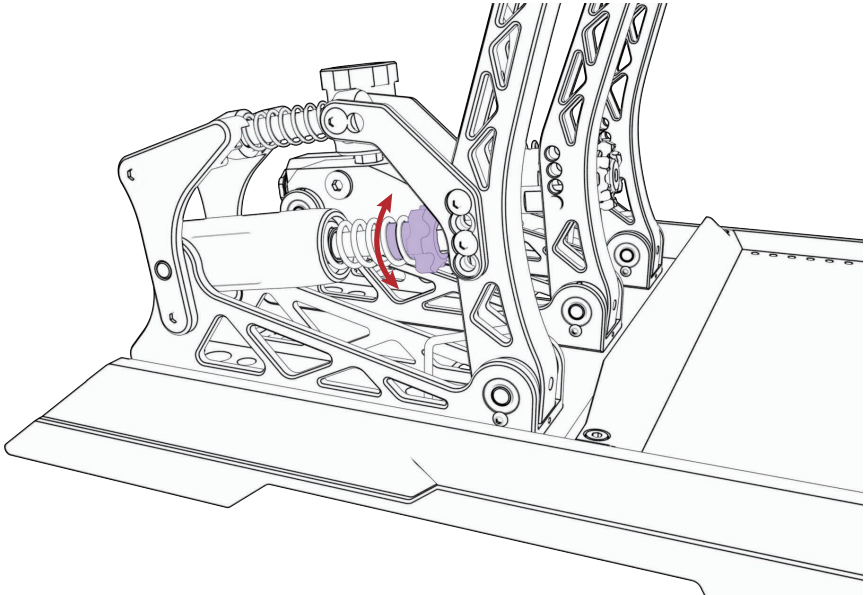

\* Visit [www.conspit.com](http://www.conspit.com) and download Conspit Link 2.0.



Please scan the QR code for reference.





***CONSPIT***